



Wireless Weather Station (P4525-WS) User manual



Rev. WL125W-12-2023

This product is to be used for educational purposes only. It is not appropriate for industrial, medical, research, or commercial applications.

The wireless weather sensor can measure temperature, humidity, barometric pressure, wind speed, wind direction, illuminance, and ultraviolet rays.

The wireless weather sensor can measure temperature, humidity, barometric pressure, wind speed, illuminance, and ultraviolet rays, and can also determine wind direction by connecting a tripod and vane. Handheld structure makes it easy to carry.

You can measure by remotely connecting to a smart device or PC wirelessly or wired.

Suggested experiments

- When measurement of various weather-related items is required
- When calculating dew point using wind speed/temperature/humidity/barometric pressure.
- When calculating perceived temperature using wind speed/ temperature/ humidity/ barometric pressure.
- When calculating absolute humidity using wind speed/temperature/humidity/air pressure.

Composition

The wireless weather sensor consists of the following.

- Wireless Weather Sensor (P4525-WS)
- Wind Vane Accessories
- Tripod
- USB-A/C cable
- Booklet

Function of wireless sensor

Structure

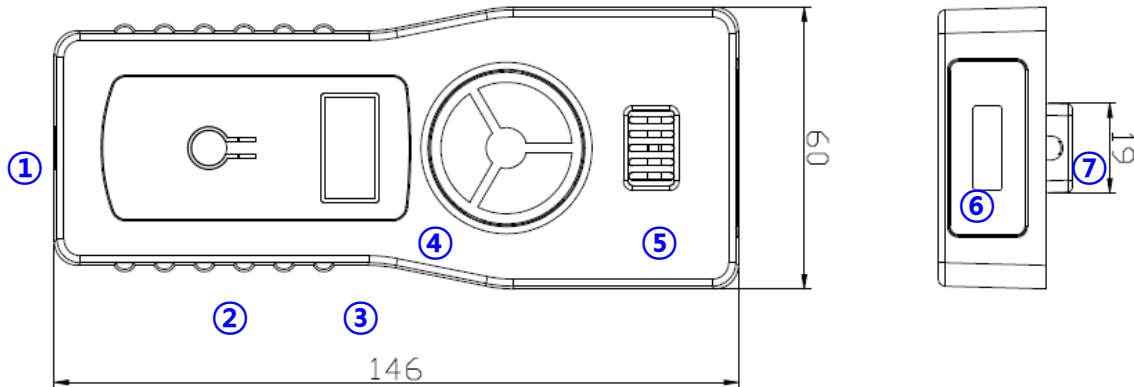

- ① USB port : Connect the sensor to a PC and use it for experiments or charging.
- ② Power/Function Button : It has functions such as power ON/OFF, measurement sensor change and calibration, etc.
- ③ OLED Display : Displays measured sensor values, sensor type, sensor ID, and remaining battery level.
- ④ Wind speed measurement unit: There is an impeller that measures wind speed.
- ⑤ Temperature/humidity/barometric pressure measurement unit: Open to allow air to flow smoothly back and forth to measure temperature, humidity, and barometric pressure.
- ⑥ Illuminance/UV measurement unit: A sensor is located inside the transparent window to measure Lux and UV index.
- ⑦ Tripod & wind vane connection: This is the part where the wing is attached to measure the wind direction.

Caution : Do not use the sensor near fire or explosive gases. High concentrations of contaminants can permanently damage the sensor.

Power/Function Button

Status	Turn	Action	Description
When the power is off	Click once	■	A short press turns the sensor on.
	Long click	■	A long press changes the mode and turns on the sensor.
When it's on	Click once	■	Change sensor type or range. (Multi-sensor or range sensor only)
	Long click	■	Turns off.

Start screen

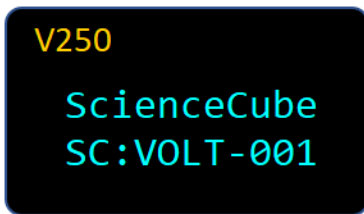

V250 : Displays the sensor's firmware version.

SC:0000-001 : When you search for a Bluetooth device, the device name will be displayed. (Sensor name and 3-digit serial number)

Mode change

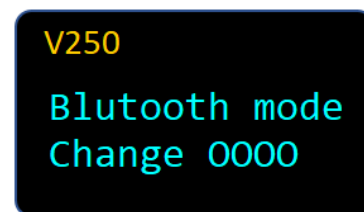

When you press and hold the power button and turn it on, the Bluetooth connection mode changes to **Mobile** or **PC** with the following message.

See last page for more information.

Measurement screen



④

① Connection mode	<p>Mobile : Connecting Android or iOS</p> <p>PC : Connecting to Windows PC</p> <p> : Connected via USB cable</p> <p>※ A long press changes the mode and turns on the sensor</p>
② Sensor-ID	This is the sensor's unique number and is displayed along with the sensor name in the device name when connected via Bluetooth.
③ Battery	Check the battery status, and when charging via USB, the display will change to charging.
④ Value	<p>1) Displays sensor measurement values and units in real time.</p> <p>2) For multiple sensors, the values for each sensor type are displayed.</p>

The measurement type changes each time you press the button.

About the Measurements

Wind Speed The sensor uses an impeller-type anemometer with the axis of rotation parallel to the direction of the wind. The motion of a magnet in the impeller produces a signal proportional to wind speed. The reading is positive regardless of the direction of motion of the impeller. It assumes that air is flowing straight into the back of the impeller. Wind speed must be at least 0.5 m/s to be measured accurately. Wind speed is measured in units of m/s, km/h, mph (miles per hour), knots, and ft/s (feet per second).

Wind direction The sensor is estimated by measuring the Earth's magnetic field. It has a built-in electronic compass, so when the weather sensor rotates along the wing, it tells you the current direction. It measures from 0 to 360 degrees and is also displayed in 16 directions.

Air Temperature The sensor is measured by the semiconductor temperature transducer. To work accurately, the transducer must be in shade. Temperature is measured on the Celsius, Fahrenheit, and Kelvin scales.

Relative Humidity The sensor is measured with a polymer-type humidity sensor. To work accurately, the transducer must be in shade and at air temperature. Relative humidity is reported as a percentage representing the ratio of the partial pressure of water vapor to the saturated vapor pressure. Relative humidity is reported as "%".

Barometric Pressure The sensor is measured by a pressure transducer inside the unit. The reported Barometric Pressure is the actual air pressure, not sea-level corrected pressure. Barometric Pressure is measured in units of mbar, hPa, and inHg (inches of mercury).

Illuminance The sensor measures the amount of light detected from above through a photodiode. Light sensor is an ambient light sensor with an integrated photodiode. It uses a photodiode whose spectral response is optimized to mimic the human eye's perception of ambient light. It is marked Lux and can be placed horizontally to observe changes in sunlight during the day.

The UV Index The sensor is a number linearly related to the intensity of sunlight reaching the earth. The UV Index has been standardized by the World Health Organization in the way shown in the table below. The higher the UVI, the greater the potential for damage to the skin and eye, and the less time it takes for harm to occur.

Sea-level Corrected Pressure

A typical weather station does not report the actual measured barometric pressure. Rather, it reports a "sea-level corrected" value. Use this formula to calculate the sea-level corrected pressure (in mbar):

$$[\text{Barometric Pressure (mbar)}] + 1013 * (1 - \exp(-h/7000))$$

where h is the sensor's elevation in m. To have this calculation done automatically, enter it in the calculator of the data collection software.

Using the Sensor

Tripod and wine vane installation

To measure wind direction, you need to combine a wing with a tripod.

1. Turn the tripod and fix it at the bottom of the circular level of the wind vane.
2. Insert the wireless weather sensor into the center bar with the front of the sensor facing the wind vane head.
3. Open the legs of the tripod at the location to be measured, then adjust the legs little by little so that the water droplet at the circular level is at the center.

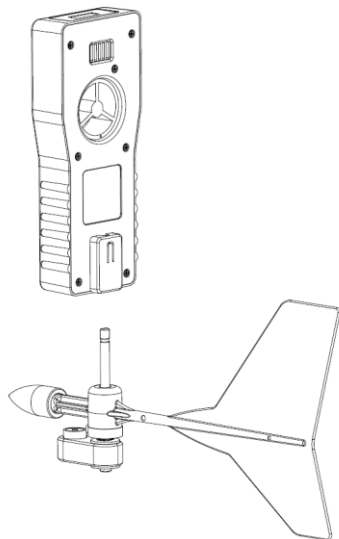

Step 1.

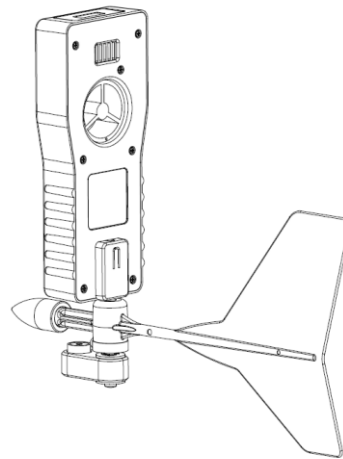

Step 2.



Step 3.

Specifications

Item	Description
Range	Temperature : -40 ~ 60 °C Humidity : 0~100 %RH Wind vane : 0~360 ° Anemometer : 0 ~ 30 m/s Illuminance : 1~188,000 lux UV Index : 0~11 index Barometer : 300 ~ 1100 hPa
Resolution	Temp. : 0.1 °C Humidity : 0.1 %RH Wind Direction : ±5 ° Wind Speed : 0.1 m/s Light Intensity : 1 lux UVI : 0.1 Barometer : 0.1hPa
Sampling Time	Max. 100Hz (0.01 sec.), (Typical 1Hz)
Condition	-40 ~ 60°C, ~85%RH
Wireless Connection	Bluetooth 5.0 or Classic 2.1
Wired Connection	USB-C
Battery	700mAh Li-Polymer rechargeable
Charging Time	within 2 hours
Operating Time	Approximately 8 hours after full charge (depending on usage conditions)
EMC	CE : EN 61326-1, EN 55011, EN 55032, EN 301 KC : R-R-KDY-WL125W

CAUTION: Do not use the instrument beyond the measurement range or in conditions that exceed the short-term exposure limits. Prolonged exposure beyond the maximum permissible range can cause serious damage to the sensor.

How to install Science#

● Install Windows PC version

Online installation file (approximately 39MB)

<http://www.koreadigital.com/url/updates/sciencesharppc/setup.exe>

* Internet connection is required during installation

Offline installation file (approximately 340MB)

http://www.koreadigital.com/url/updates/sciencesharppc/setup_full.exe

* Installation does not require an Internet connection, but contains large content

● Install from a mobile smart device (Smartphone or Tablet PC)

1. Download Science# to your smart device (Refer to QR codes below)
2. Connect using Bluetooth (See Science# documentation or refer to next page)
3. Run Science#
4. When you connect the sensor, the measurement is displayed on the Science# screen



Features

- Up to four wireless sensors can be connected to a PC or smart device at the same time.
- It supports dual-mode Bluetooth, allowing you to connect not only smart devices but also desktop and laptop PCs to conduct experiments using the Science# application.
- It can be connected to a PC through a USB port and experiments can be performed using the Science# program.

How to connect Wireless Sensor to Science# program

● Windows PC

1. Install and run Science# (Refer to previous page for installation method)
2. Power on the sensor
3. Click the  [Connect] icon and select [Bluetooth Interface] from [Select Interface]
4. [Add Bluetooth or other device] → [Bluetooth] → Add sensor number after checking the number on the backside of sensor
5. When you see like the picture, click on Wireless Sensor and connect

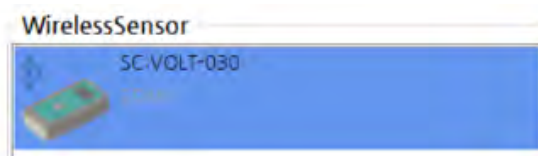

● Android or iOS (Smartphone or Tablet PC)

1. Install and run Science# (Refer to previous page for installation method)
2. Power on the sensor
3. Click the  [Connect] icon and select [Bluetooth Interface]
4. After selecting the device search, check the sensor number on the backside and connect



If you experience any connection issues, check Bluetooth mode on the sensor. Please refer to the next page for instructions on how to change it.

How to switch to Bluetooth mode for Android and iOS

For mobile devices (Android, iOS) Bluetooth Low Energy technology is used for wireless communication. For these devices do not pair the sensor just use it directly in the software.

Turn off the sensor. Then press and hold the power button until the text 'Bluetooth mode Change Mobile' is shown, then release the button. The mode is set to 'Mobile', meaning that Bluetooth Low Energy is used.

How to switch to Bluetooth mode for Windows

For Windows computers, Bluetooth Classic technology is used for wireless communication. Before you start to use the sensor for measurement you have to pair it. If you are asked for a PIN, enter either "1234" or "0000".

Turn off the sensor. Then press and hold the power button until the text 'Bluetooth mode Change PC' is shown, then release the button. The mode is set to 'PC', meaning Bluetooth Classic is used.

Rev. WL125W-12-2023

Copyright (c) Korea Science Digital Co., Ltd. All rights reserved. The contents of this manual are for informational purposes only and we cannot be held responsible for errors or misleading information that may appear in this manual. The specifications and functions of the product are subject to change without prior notice.

 and ScienceCube are registered trademark of Korea Digital Co., Ltd.

Science Cube Light, Science Cube Pro, Free Linker, and Max are trademarks of Korea Digital Co., Ltd.

Windows and Excel are registered trademarks or trademarks of MicroSoft.

All other trademarks are the property of their respective owners.